



Stationary Drive Over Truck Unloader. 1200 TPH capacity with fold out wing walls



Drive Over Unloader can be used with standard belly dumps as well as end dumps



Stationary Side-Dump Truck Unloader



Drive Over Unloader transferring material to stockpile via (2) 36" collecting conveyors and 42" dogleg conveyor



MASABA Mining Equipment  
1617 317th Street  
PO Box 345  
Vermillion, SD 57069

Toll Free: 877-MASABA-0 (877-627-2220)  
Direct: 605-624-9555  
Fax: 605-624-8997  
Canadian Office: 905-453-2200  
Web: www.MASABAINC.com

**5 Year** Complete Structural  
**2 Year** Complete Equipment  
**WARRANTY**



**MASABA**<sup>®</sup>  
MINING EQUIPMENT



**MASABA**<sup>®</sup>  
MINING EQUIPMENT

**STRENGTH YOU  
CAN DEPEND ON**

# TRUCK UNLOADERS

Custom 72" Low Profile Truck Unloader with adjustable discharge height and self-cleaning ramps



**The Most Complete Line of  
Customized Material Handling Solutions**

## TRUCK UNLOADERS



Custom 48" Low Profile Truck Unloader with fixed discharge height – shown in road travel position

### 48" and 72" Configurations Completely CUSTOMIZABLE for Your Application

- No Earthen Ramps Required!
- Fast Set Up Time
- Designed for Ease of Maintenance
- Removable **HEAVY DUTY** Drive Over Grizzly Bars
- Customizable up to 40 Ton Haul Trucks
- Up to 1,500 STPH @ 100 PCF

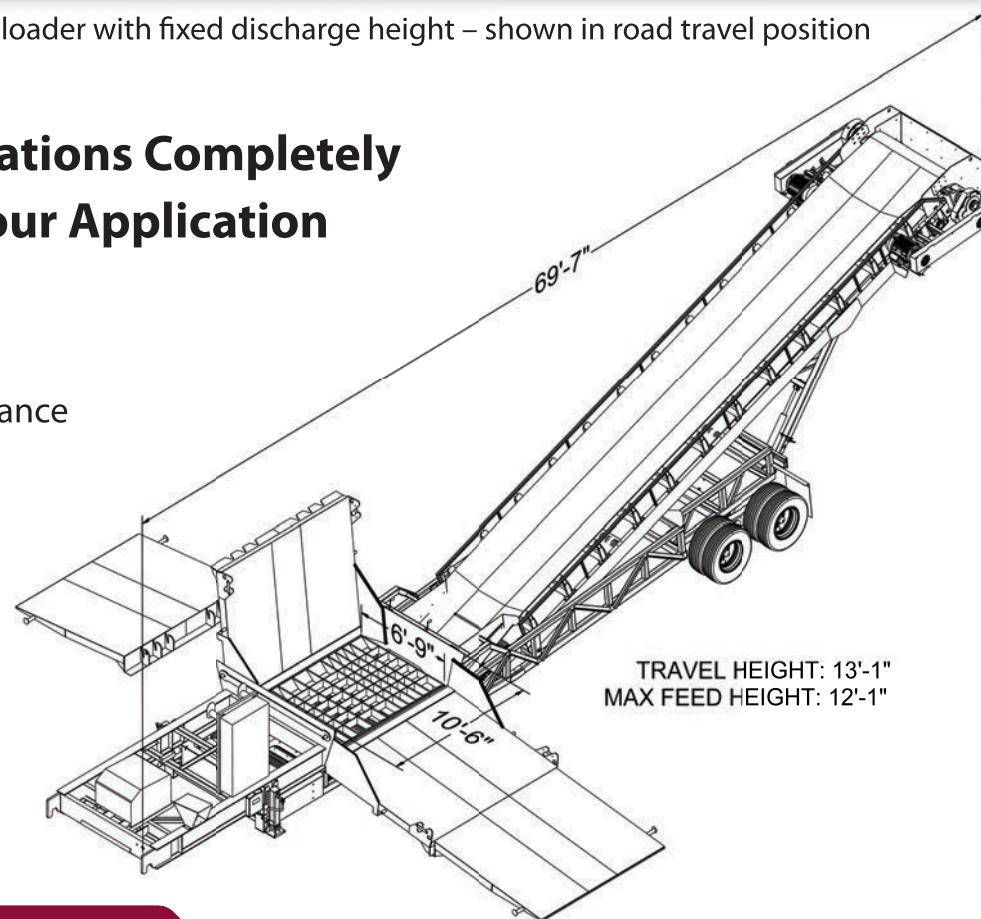

Variable Height Hydraulic Raise, Heavy Duty Hood w/ Optional Wear Plates

#### Features

- 48" & 72" Belt Widths
- **HEAVY DUTY** Design
- Self-Cleaning Hydraulic Ramps
- Class II Dual Drive (**Optional Wrap Drive**)
- On Board Steel Ramps (No Earthen Ramps Required)
- Hydraulically Adjustable Discharge Height
- Custom Hoppers Available to Quickly Convert into Load Out Hopper (See photo below)

#### BENEFITS OF MASABA TRUCK UNLOADERS

- Savings in labor, fuel, maintenance
- Reduce multiple handling of material
- Eliminate traffic congestion of multiple trucks and loaders
- Hydraulically folding self-cleaning ramps



| MASABA LP Truck Unloaders           | 48"                      | 72"                      |
|-------------------------------------|--------------------------|--------------------------|
| Conveyor Length                     | 45'                      | 56'                      |
| Discharge Height                    | Hydraulically Adjustable | Hydraulically Adjustable |
| Capacity (@ 100 PCF)                | Up to 1,000 STPH         | Up to 1,500 STPH         |
| Class II Dual Drive                 | Qty (2) 25 HP            | Qty (2) 40 HP            |
| Earthen Ramps                       | Not Required             | Not Required             |
| HEAVY DUTY American Made Components | Standard                 | Standard                 |
| Remote Control                      | Optional                 | Optional                 |
| Electrical Components               | All NEMA Components      | All NEMA Components      |